

SPALDING SPECIFICATIONS

DATE: 01/01/06

MODEL NUMBER: 0401870

DESCRIPTION: Curtain Regulation System

1. The successful vendor agrees to furnish and install sufficient infrared sensing devices, with the approved guards, to detect any personnel obstructions along the entire length of the path of the operable partition (no more than seven (7) feet, no less than three (3) feet to both sides) during opening and closing modes.
 - A. Passive Infrared Detectors "PULNIX" model # SP-100 XS Sensitivity (PIR) shall be capable of wall or ceiling surface mounting, self-contained, self-monitoring circuit operating on 12 VDC input power and have adjustable internal optics. Optics shall be focused to provide the narrowest detection corridor adjacent to the doors that assures reliable detection. The operator control switches shall be positioned as close to the detection corridor as possible without causing the operator to cause an unintended detection/alarm. Each Long-Range PIR Detector shall provide a **minimum of twenty-two (22)** individual zones of detection. A solid infrared barrier must be achieved and be free of voids between detection zones. PIR detectors which permit voids in the infrared barrier and do not provide 100% coverage are unacceptable.
 - B. PIR guards shall be constructed of sheet metal with hi-temperature baked white enamel finish or an approved equal. Guard shall be independently fastened to the wall or ceiling with a least four approved fastening devices.
 - C. The infrared safety system must be designed to work as an integral part of the operable partition system. While the partition is in operation a **minimum of two (2) infrared sensors** monitor **each side** of the partition for movement and immediately disengages the motor upon the "safety zone" being interrupted. These infrared beams must span the entire path of the partition on both sides, a **minimum of four (4) sensors** being used. Long range sensors shall be wall mounted 9-12 feet from floor (higher on wall or ceiling mount per site condition) and be covered by a sheet metal protective housing. The protective housing must be sheet metal so as to minimize dust collecting on the lens. An additional **two (2) pocket/stack sensors** "OPTEX" model # CX-502 AM (PIR) shall be capable of wall or ceiling mounting self-contained self monitoring circuit, anti-masking technology, operating on 12 VDC input power, must be mounted at the entrance of pocketed areas or behind stacked panels. These sensors will detect intrusion into these critical areas at any point during the operation cycle, (whether the partition is at rest or in motion) and render the operable partition inoperable until keyed reset switches mounted **(1) on each side** of the partition are engaged. Additional sensors will be installed as site conditions warrant.
 - D. Photo-electric, point to point sensors mounted below 8' AFF will not be acceptable.
 - E. Provide and install required signage for safe operating procedures.
2. The successful vendor agrees to install a lockable system control panel (SCP) of suitable size to house the following equipment:
 - A. Terminal strip of sufficient size, for each connection into panel.
 - B. Complete circuit control board.
 - C. Two (2) 12 VDC relay devices.
 - D. Resistors, resistor blocks interwiring.
 - E. Power supply capable of additional components of various types.
 - F. Alternate voltage switching device.
 - G. Suitable barrier for voltage separation.
 - H. SCP shall be located adjacent to existing electrical drive system area and include code security tag, sealing enclosure.

3. Vendor agrees to furnish and install, in gym ceiling an alarm-warning device to be activated for fifteen (15) seconds when system sensed any obstruction and stops the movement of door. Warning alarm device shall be Sound Bomb Type PIEZO warning device alert with 100 decibels output, with high and low settings or an approved equal. This device is integral to the system control panel.
4. Vendor agrees to furnish and install (2) surfaced mounted, two gang boxes, with stainless steel face plates and tamper proof screws, a manual key operated arming and disarming switch with a red LED indicator for armed position and green LED indicator for AC power and two (2) spring loaded, key operated switches to control operation of moving door in both directions. This control box or boxes shall be located outside of the detection zones created by the PIR Detectors. This will insure safe and proper operating procedures.
 - A. A prominent safety sign is to be provided at each key control station location. Sign text to read "**Warning-Electrically Powered Partition. Only appropriate trained staff may operate this partition. Control stations must be attended by staff members while the partition is in motion. Staff members must stand on opposite sides of partition during stacking or extending procedure. Students must stay away from partition while in motion.** Or approved equal text. Sign shall be of durable construction, professional in manufacture and appearance and securely fastened in place.
5.
 - A. Vendor agrees to furnish and install all interwiring of suitable size, and raceways from the nearest electrical box. Make the proper connections to all items. Minimum size raceway from low voltage conductors shall be ½ inch. Minimum size raceway for power shall be ¾ inch.
 - B. Existing conduits may be used where allowed by code. Flexible conduits may be used in concealed locations. Metal moldings shall be utilized in offices.
 - C. All power wiring shall be THHN, minimum size #12. Low voltage wiring shall be 22 gauge, twisted, unshielded, copper, vinyl insulated, UL listed. Low voltage conductors shall not be placed in the same raceway, outlet box junction box or fitting containing electrical power, unless a suitable barrier is provided.
 - D. All equipment shall be installed in a fail-safe manner such that the failure of any safety device shall render the electrically operated partition inoperable until such device is repaired.

Installation Instructions

The following drawing shows how the Curtain Regulation System should be installed in a gymnasium:

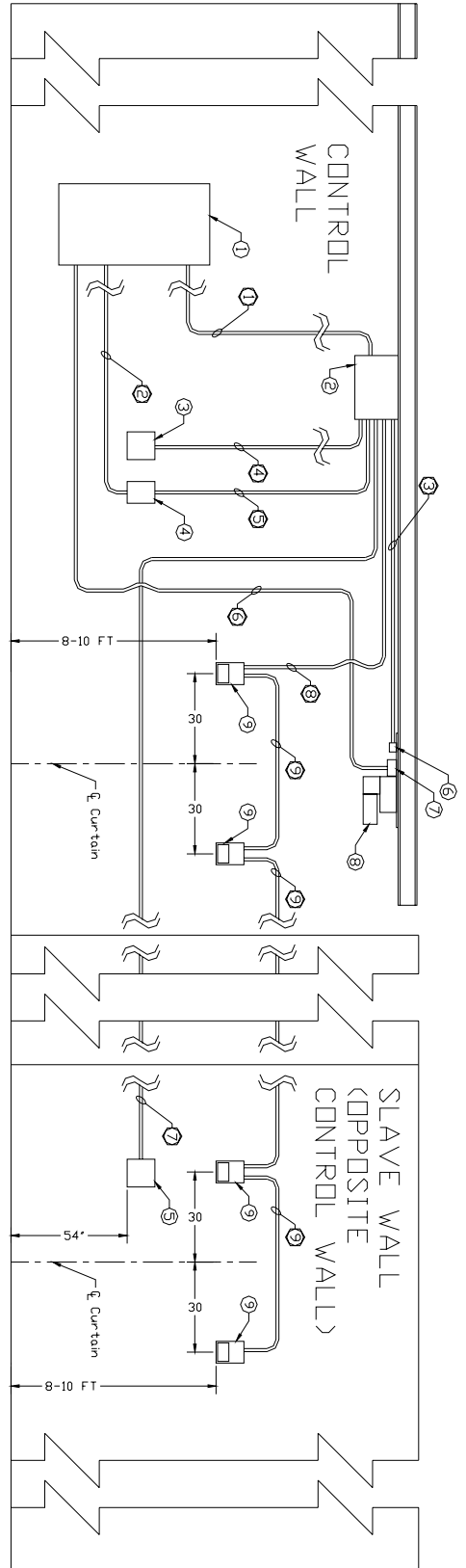

ITEM	DESCRIPTION OF COMPONENT	NOTES	WIRE	DESCRIPTION OF WIRES	ORIGIN	TERMINUS	NOTES
①	BREAKER BOX	②	①	3-#12 THHN WIRES	①	②	① ② ③ ④
②	CURTAIN REGULATION SYSTEM MAIN PANEL	②	②	3-#12 THHN WIRES	①	④	① ② ③ ④
③	MASTER STATION	②	③	2-#12 THHN WIRES	②	⑥	① ② ④
④	MASTER KEY SWITCH	②	④	4-#22 THHN WIRES	③	②	① ②
⑤	SLAVE KEY SWITCH	② ④	⑤	2-#12 THHN WIRES	④	②	① ②
⑥	LIMIT SWITCH	②	⑥	2-#12 THHN WIRES	①	⑦	① ② ③ ④
⑦	MOTOR ASSY JBOX	②	⑦	4-#22 THHN WIRES	②	⑤	① ②
⑧	MOTOR ASSY	②	⑧	4-#22 THHN WIRES	②	⑤	① ②
⑨	INFRARED SENSOR WITH COVER	②	⑨	4-#22 THHN WIRES	③	⑤	① ②

NOTES:

- ① ALL WIRING TO BE COMPLETED BY AN ELECTRICIAN LICENSED BY ALL NECESSARY LOCAL, STATE AND NATIONAL AUTHORITIES.
- ② ALL WIRING, CONDUIT, COMPONENTS AND INSTALLATION TECHNIQUES TO MEET ALL LOCAL, STATE AND NATIONAL CODES.
- ③ 115 VAC SINGLE PHASE 60 HZ POWER SUPPLY WITH 15 AMP BREAKER.
- ④ WIRE SIZE RECOMMENDED BASED ON TYPICAL RUN LENGTH. LONGER RUNS MAY REQUIRE LARGER WIRE SIZE TO MAINTAIN 115 VAC @ 15 AMPS. LICENSED ELECTRICIAN SHOULD SIZE WIRE IN ACCORDANCE WITH ALL LOCAL, STATE AND NATIONAL CODES.

Wiring Instructions

Wire between components according to the following wiring schematic.

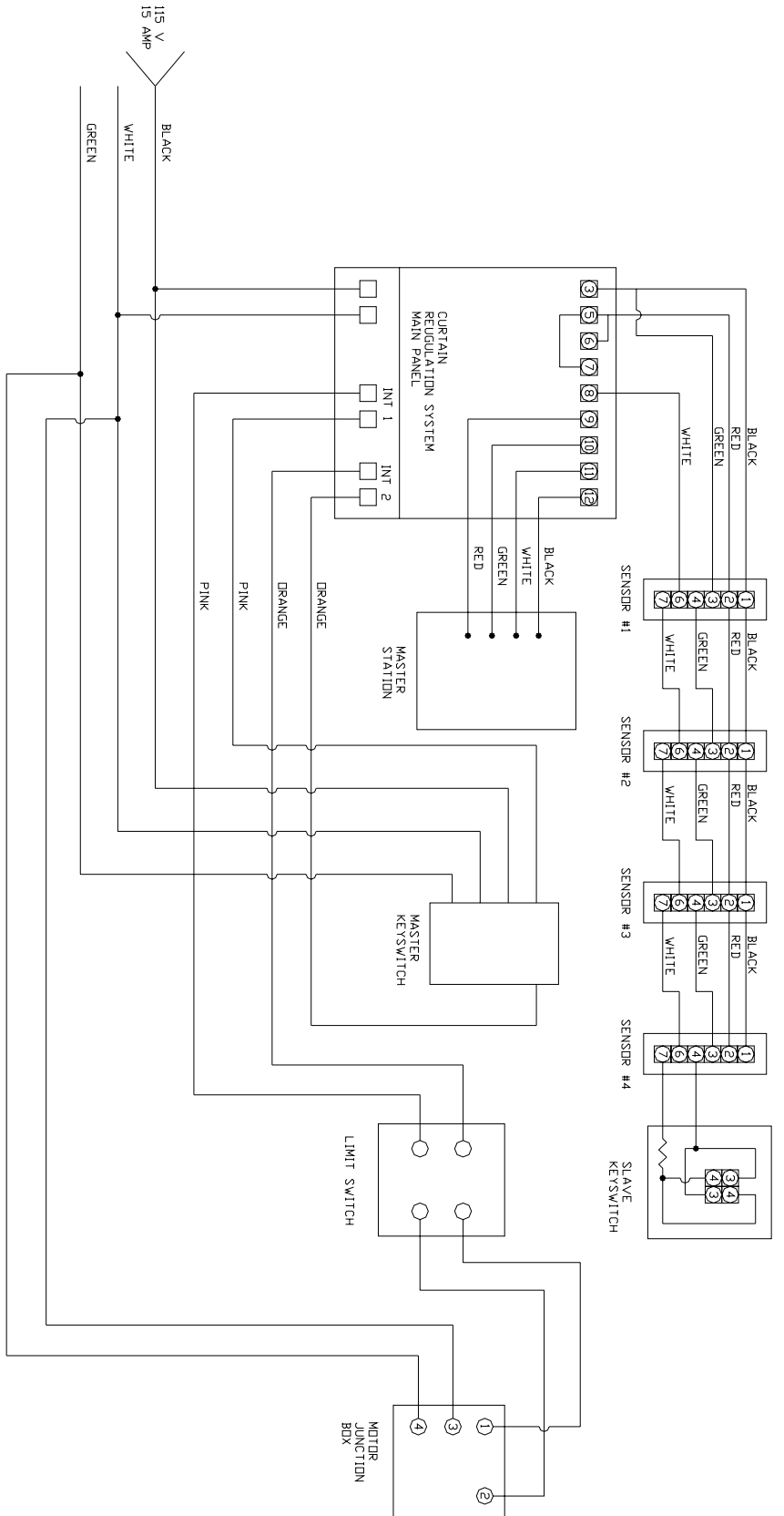

NOTES: ① THE FOLLOWING IS A KEY TO IDENTIFYING THE TERMINALS OF THE OPTEX SENSORS:

- | | | | |
|---|------------|---|-------|
| ① | NEGATIVE | ① | BLACK |
| ② | POSITIVE | ② | RED |
| ③ | 1ST ALARM | ③ | GREEN |
| ④ | 2ND ALARM | ④ | WHITE |
| ⑤ | 1ST TAMPER | ⑤ | GREEN |
| ⑥ | 2ND TAMPER | ⑥ | RED |
| ⑦ | | ⑦ | WHITE |

② TERMINALS 5 & 6 AND 5 & 7 MUST BE JUMPED IN THE FIELD AS SHOWN ON THIS SCHEMATIC.

WIRING
DIAGRAM